

J. I. HOLCOMB & J. F. HOKE, Jr.

POPCORN MACHINE.

APPLICATION FILED DEC. 28, 1914.

1,195,017.

Patented Aug. 15, 1916.

4 SHEETS—SHEET 1.

Fig. 1.

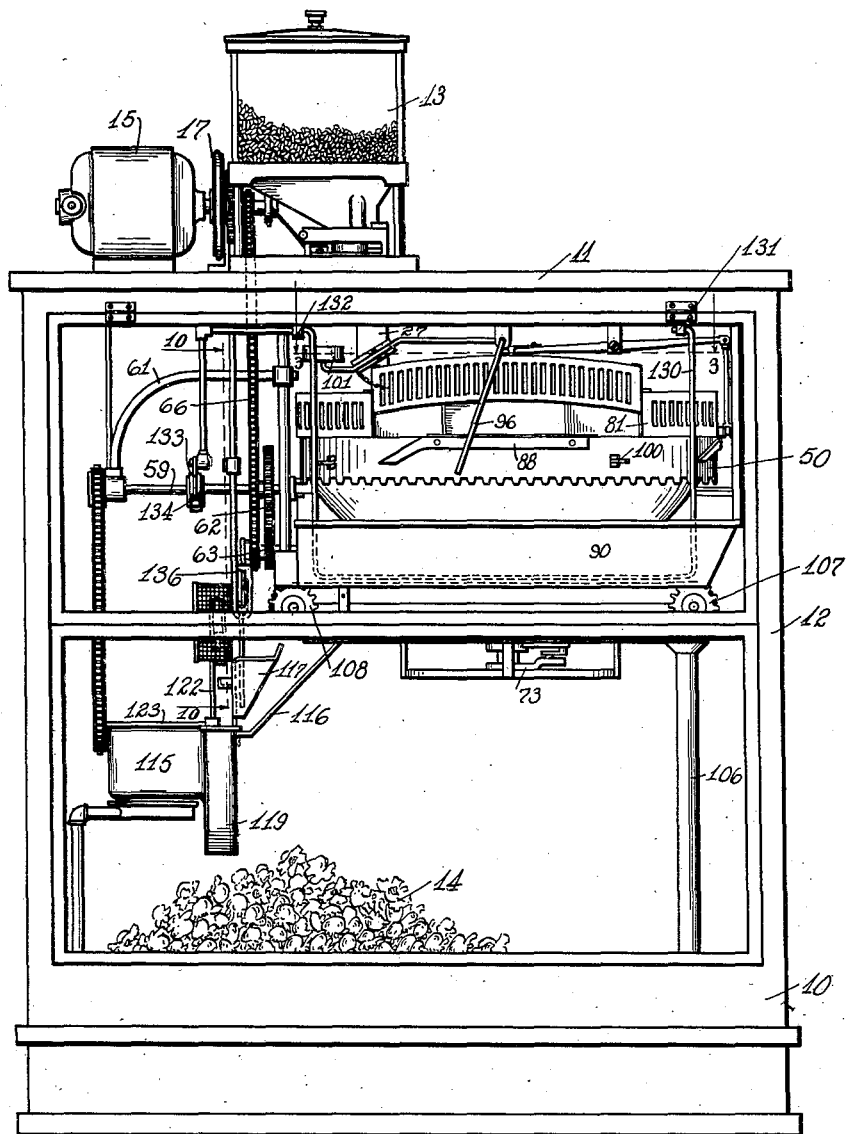

WITNESSES:

A. H. Edgerton
R. H. Lockwood

INVENTORS

James I. Holcomb +

Jacob F. Hoke Jr.

BY

R. H. Lockwood.

ATTORNEY

J. I. HOLCOMB & J. F. HOKE, JR.
POPCORN MACHINE.
APPLICATION FILED DEC. 28, 1914.

1,195,017.

Patented Aug. 15, 1916.
4 SHEETS—SHEET 2.

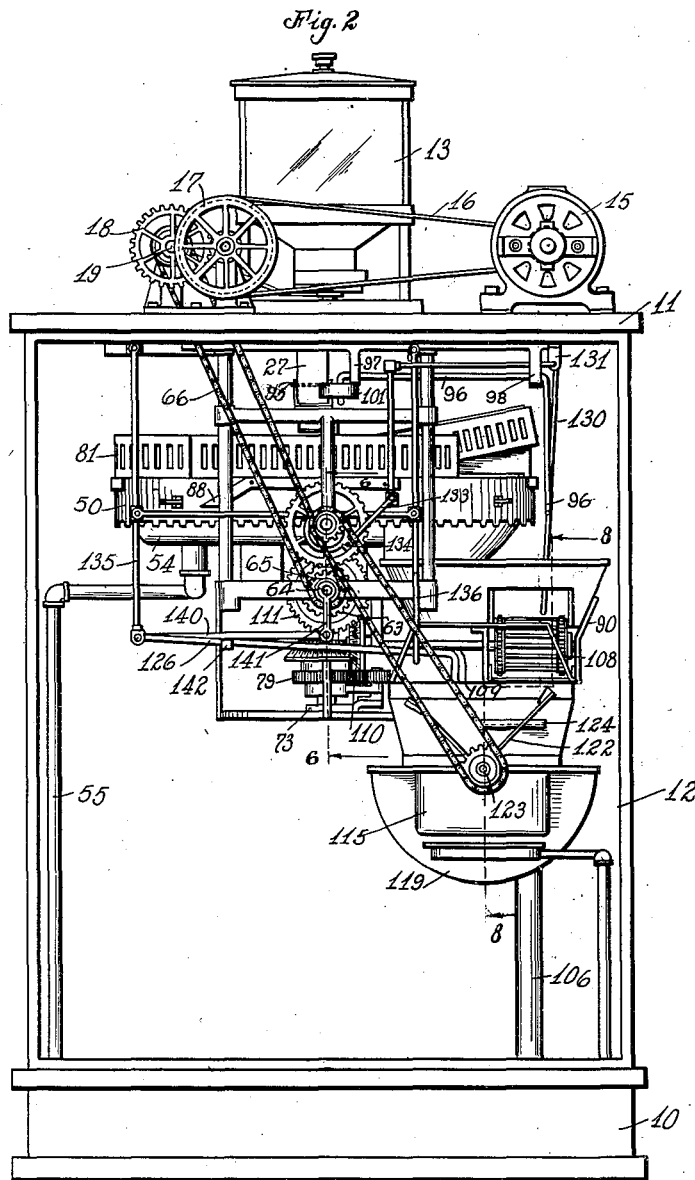

WITNESSES:

AH Eckertson
R. H. Wood

INVENTOR

James I. Holcomb +

Jacob F. Hoke Jr.

BY

R. H. Wood
ATTORNEY

J. I. HOLCOMB & J. F. HOKE, JR.
 POPCORN MACHINE.
 APPLICATION FILED DEC. 28, 1914.

1,195,017.

Patented Aug. 15, 1916.

4 SHEETS—SHEET 3.

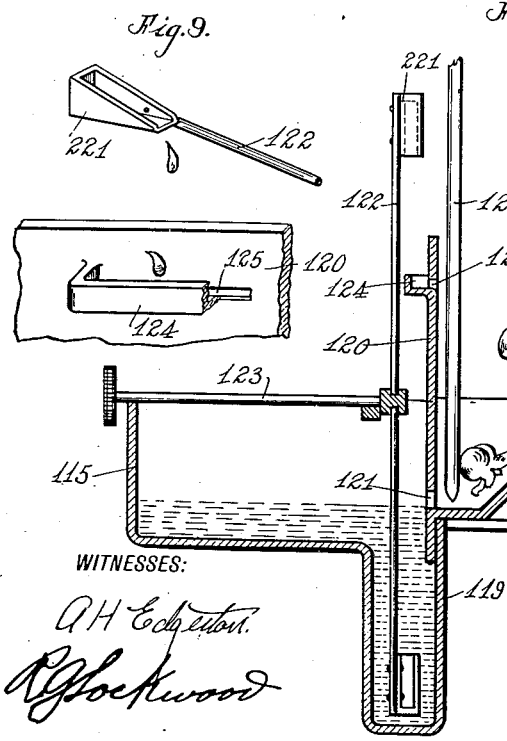
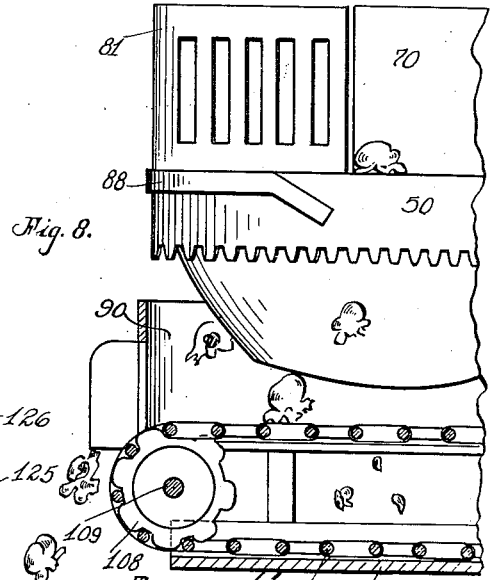
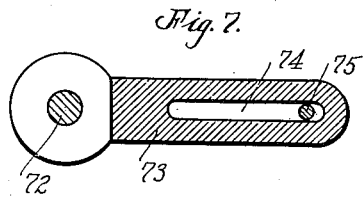
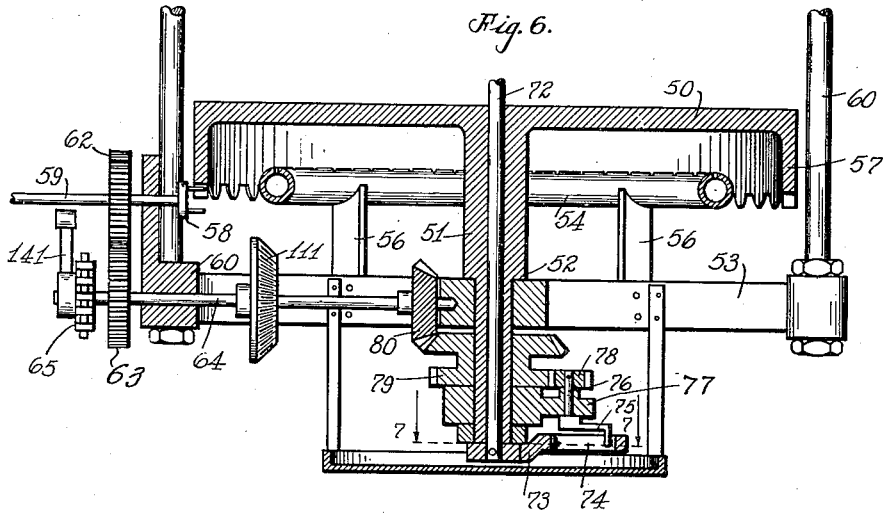

WITNESSES:
A. H. Edgerly
R. Lockwood

INVENTOR
 James I. Holcomb +
 Jacob F. Hoke Jr.
 BY
R. H. Lockwood
 ATTORNEY

J. I. HOLCOMB & J. F. HOKE, JR.
 POPCORN MACHINE.
 APPLICATION FILED DEC. 28, 1914.

1,195,017.

Patented Aug. 15, 1916.

4 SHEETS—SHEET 4.

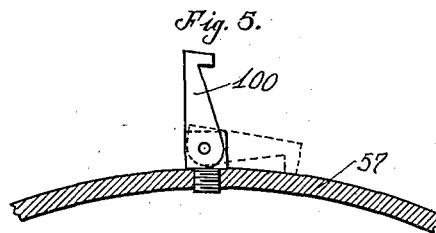
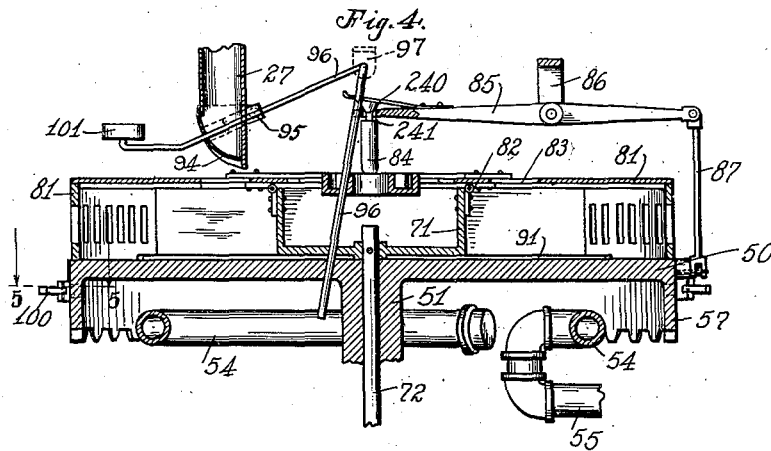
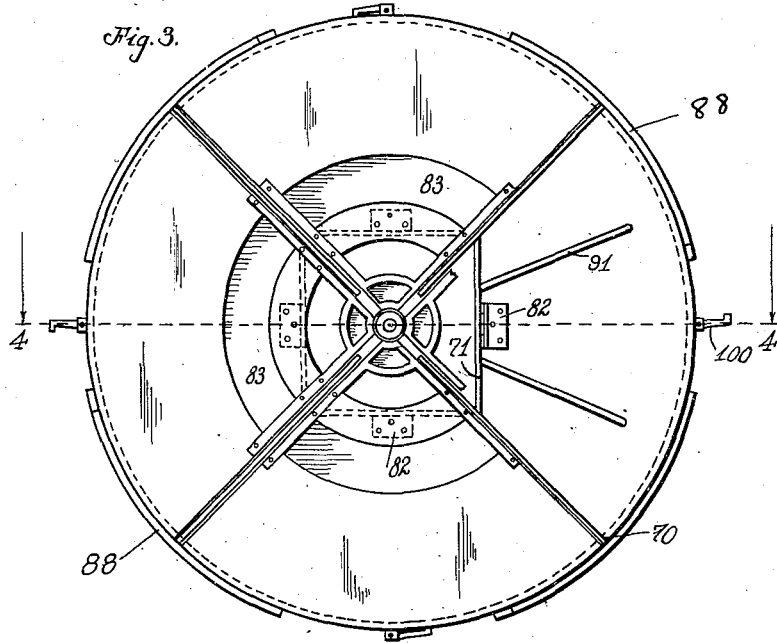

WITNESSES:

A. H. Edgerton
R. G. Lockwood

INVENTOR

James I. Holcomb +
 Jacob F. Hoke Jr.

BY

V. H. Lockwood,
 ATTORNEY

UNITED STATES PATENT OFFICE.

JAMES I. HOLCOMB AND JACOB F. HOKE, JR., OF INDIANAPOLIS, INDIANA.

POPCORN-MACHINE.

1,195,017.

Specification of Letters Patent. Patented Aug. 15, 1916.

Application filed December 28, 1914. Serial No. 879,396.

To all whom it may concern:

Be it known that we, JAMES I. HOLCOMB and JACOB F. HOKE, Jr., citizens of the United States, and residents of Indianapolis, county of Marion, and State of Indiana, have invented a certain new and useful Popcorn-Machine; and we do hereby declare that the following is a full, clear, and exact description thereof, reference being had to the accompanying drawings, in which like letters refer to like parts.

The object of this invention is to improve the construction of continuously operated corn popping machines.

One feature of the invention consists in providing a finger on the popping plate for controlling the feed into one or more of the compartments of the popper cage so that the amount of corn supplied to each compartment thereof will be regulated and hence the capacity of the machine controlled, although it is continuously operative.

By this invention when there is a reasonable supply of popped corn, the machine may be adjusted so that thereafter it will pop only one-half as fast or one-fourth as fast as the full capacity. Therefore, the output of the continuously operated machine can be regulated to suit the demand.

Another feature of the invention consists in locating the bearings for mounting the rotary popper at a point below the burner for heating the popping plate of the popper so that the heat transferred will not injure or affect the bearings or interfere with the lubricating oil therein.

The full nature of the invention will be understood from the accompanying drawings and the following description and claims:

In the drawings, Figure 1 is a front elevation of the machine. Fig. 2 is an elevation of the left-hand side. Fig. 3 is a section on the line 3-3 of Fig. 1. Fig. 4 is a section on the line 4-4 of Fig. 3. Fig. 5 is a section on the line 5-5 of Fig. 4. Fig. 6 is a section on the line 6-6 of Fig. 2. Fig. 7 is a section on the line 7-7 of Fig. 6. Fig. 8 is a section on the line 8-8 of Fig. 2. Fig. 9 is a perspective view of portions of the device shown in Fig. 8.

The mechanism of this device is preferably arranged to be entirely visible to purchasers; hence, the case has a bottom 10, top 11 and four sides 12 of glass. The popcorn is in a receptacle 13 on top of the machine and the

popped corn 14 is in the bottom of the case, as shown in Fig. 1. Upon the case there is a motor 15 for driving the machine through a belt 16 running to a pulley 17 which in turn drives a gear 18 on a shaft 19. The popcorn is fed down from the receptacle 13 by means actuated by said shaft 19 and is discharged to the popping mechanism through a chute 27, see Fig. 4.

The popping mechanism includes a popping plate 50 which is driven constantly, but very slowly. It has a central downwardly extending sleeve 51 which has a shoulder bearing 52 on a frame member 53 and the popping plate is heated by an annular burner 54 through which gas is supplied through a pipe 55. The burner is supported on the frame 53 by uprights 56. The popping plate has an upper surface with a rimless marginal portion and a downwardly extending toothed flange 57 which is engaged by a pin wheel 58 and the popping plate thereby driven. Said pin wheel 58 is secured on a shaft 59 mounted in one of the frame members 60 and an arm 61 therefrom and is driven by a gear 62 and pinion 63, the latter being on a shaft 64, as shown in Fig. 6, and said shaft is driven by a sprocket wheel 65 driven by a chain 66 from a sprocket wheel on shaft 19, as shown in Fig. 2.

The popcorn is held upon the popping plate by a cage 70, see Figs. 3 and 4. This cage includes a square center frame 71 and four radial partitions equidistant from each other and said frame is rigidly secured to a vertical shaft 72 which extends down through the popping plate and sleeve 51 on the lower end of which an arm 73 is secured, as shown in Figs. 6 and 7. This arm has a longitudinal slot 74 in which a crank 75 loosely operates, said crank being secured on a shaft 76 in a bearing 77 fixed on the lower part of the sleeve 51. The shaft 76 is driven by a pinion 78 which meshes with a gear 79 loosely mounted on the lower part of the sleeve 51 and said gear is driven by a bevel gear 80 on the shaft 64 meshing with a bevel gear on gear 79. The shaft 64 is constantly driven, but the crank 75 oscillates the arm 73 and, therefore, causes a corresponding oscillatory movement of the frame 71 for causing the popcorn to be shaken or agitated on the popping plate and keep it from burning while becoming heated. Said cage 70 is provided with four compartments having vertical oscillatory doors 81 with the tops

thereof hinged to the center frame 71 by hinges 82. The doors are segmental in shape and have a top portion and a curved perforated peripheral portion. The top of each door has a concentric slot 83 for the admission of the popcorn from the chute 27, as shown in Fig. 4.

In the operation of the popping mechanism the charge of corn is in one of said compartments and rests upon the popping plate which is heated and constantly rotated while the cage is constantly oscillated and thus the corn is kept in motion. The cage not only oscillates independently of the popping plate, but has a general rotary movement along with the popping plate so that when the popping plate makes a quarter revolution, the popcorn will be heated and a second quarter revolution will find the popcorn popping, while the popping will be completed during the third quarter of the revolution and be discharged during the fourth quarter of the revolution and will be dried during the second, third and fourth quarters of the revolution so that popcorn will issue from the popping mechanism not only popped, but thoroughly dried to perfect the quality of the popped corn.

The hinge 82 is located between the outer and inner ends of the door top so that by pressing down on the inner apex of such door, the door will be opened, as shown in Figs. 1 and 2. Means for opening said door is seen in Fig. 4 where a pin 84 is pivotally mounted on the inner end of a lever 85 fulcrumed between its ends to a fulcrum 86 and is actuated through a downwardly extending rod 87 which is elevated by a cam bar 88 secured to the periphery of the popping plate opposite each compartment of the cage. As shown in the upper right-hand corner of Fig. 1, said lever mechanism is opening a door of the cage and while said door is opened or elevated as shown, the popcorn discharges over the periphery of the popping plate into a receptacle 90 below, as seen in Fig. 1. The popcorn is caused to discharge by the agitating arms 91, see Figs. 3 and 4, connected with the center frame 71 and projecting radially outward into the chamber for the popcorn. Since these arms have oscillatory movement along with the cage, they force the popcorn over the edge of the popping plate.

The feed of the popcorn from the chute 27 to the proper compartment of the cage is controlled by a door 94 pivoted on a pivot 95 to the lower end of the chute so as to close or open the chute and is oscillated by a crank rod 96 mounted in two arms 97 and 98, as shown in Fig. 2, which rod is actuated by a finger 100 pivoted to the periphery of the popping plate opposite the middle of each compartment of the cage, as shown in Fig. 3. When said finger extends radially

outward, as in Fig. 5, it will engage the end of said crank rod 96, as seen in Fig. 1, and open the door 94. A weight 101 on the other end of the crank rod 96 will return it to closing position. By turning some of said fingers 100 to the dotted line position shown in Fig. 5 so that they will not engage the crank rod 96, popcorn will not be fed to the corresponding compartment. Thus if said fingers are arranged as shown in Fig. 3, popcorn would be fed only to the left-hand and right-hand compartments and thus the capacity of the machine be diminished one-half. By this means one is enabled to control the capacity of the machine so as to pop corn slowly or fast, as desired.

The receptacle 90 for receiving the popped corn from the popping plate, as shown in Fig. 8, has its inner side extending higher than its outer side and in the lower part of said receptacle a conveyer 105, operates for conveying the popped corn to the buttering mechanism. This conveyer is formed of spaced bars wide enough to let the unpopped corn pass through it, whereupon the unpopped corn is moved by the lower part of the conveyer which is moving away from the buttering mechanism to a point of discharge. The large and perfect grains cannot pass through the conveyer. The conveyer is mounted at the right-hand end, as shown in Fig. 1, on an idle sprocket 107 and at the other end is carried by a driving sprocket 108 on a driving shaft 109, which has secured on it a bevel gear 110, see Fig. 2, which engages a bevel gear 111 on the shaft 64, as shown in Fig. 6. In order to agitate the popcorn while it is on the conveyer and cause the unpopped corn to be separated, a crank rod 130 is pivoted in brackets 131 and 132, as shown in Fig. 1, and so that the rod can rock and it extends in the receptacle and rocks over the conveyer. The rocking movement is caused by a connecting rod 133 running to an eccentric 134 on the shaft 59. That causes the bar 130 to rock transversely across the conveyer and agitate the popped corn.

Under the discharge end of the conveyer there is a buttering mechanism consisting of a vessel 115 supported by frame bars 116 and having an inclined side 117 projecting beneath the discharge end of the conveyer and it also has a recessed chamber 119 and a stationary partition plate 120 with perforations 121 to permit the butter which is discharged into the chamber at the right-hand side of the partition 120 to flow back into the main chamber, but prevent the popped corn following the butter. The parts 117 and 120, therefore, constitute a popcorn receiving chamber on a higher level than the chamber 119 containing the greater portion of the butter. The butter is elevated by cups 221 on the ends of arms 122 carried

by a horizontal shaft 123. As each cup passes through the butter in chamber 119, it will be filled with butter and as it is revolved and passes over center, it will discharge the butter into a trough 124 from which the butter flows through an opening 125 down the right-hand wall of the plate 120 and engages the popped corn as it is rubbed against said wall by a movable finger 126. The horizontal portion of said finger 126 is pivotally mounted in the lower end of a bar 135 and the other end of said finger 126 lies loosely in the slotted lower end of a bar 136 so that the finger can rise and fall. Said bars are pivoted to the top at 137 and are connected by a pivot bar 138. The frame of the bars 135, 136 and 138 is rocked by a connecting rod 140 pivoted thereto and to a crank 141 on the shaft 64, see Fig. 6. The horizontal portion of the finger 126 slides on a fixed bar 142, see Fig. 2, and as the frame is rocked, the frame and bar 142 cooperate to cause the vertical as well as the longitudinal movement of the finger 126, whereby it agitates the popcorn.

The lever 85 has secured upon it a flat spring 240, as shown in Fig. 4, which is secured to the upwardly flaring end of the pin 84. Said pin is reduced between its ends and the reduced portion extends through a hole 241 in said lever. This enables the pin 84 to have some freedom of movement and adapt it to engage the inner ends of the compartment tops 81 and yet be returned to normal position always by the spring 240.

The invention claimed is:

1. In a corn popping machine, a rotary popping plate, means for feeding thereto the corn to be popped, means for regulating the feed of the popcorn to said popping means, and pivoted means on the margin of said popping plate for engaging and operating said feed regulating means.

2. In a corn popping machine, rotary popping means, means for feeding thereto the corn to be popped, means for regulating the feed of the popcorn to said popping means, and fingers pivoted to said popping means so that they can be moved into position to engage and actuate said feeding means.

3. In a corn popping machine, rotary popping means, means for feeding thereto the corn to be popped, means for regulating the operation of said feeding means having an arm projecting down beside the periphery of the popping plate, and fingers pivoted in a horizontal position to the periphery of said popping plate adapted when turned radially outward to engage said arm and operate the feeding mechanism and when turned inwardly against the periphery of the popping plate, to not engage said feed operating arm.

4. In a corn popping machine, rotary popping means divided into compartments,

means for feeding the corn to be popped into one compartment at a time, means for controlling said feeding means having an arm extending down beside the periphery of the popping means, and a finger pivotally mounted on the periphery of said popping means opposite each compartment and adapted to be adjusted into and out of position to engage said arm, whereby the corn to be popped may be fed only to such compartments as desired.

5. A corn popping machine including a rotary popping plate, a cover thereon divided into compartments, a feeding chute adapted to discharge corn into one compartment at a time, means for controlling said feeding chute having an arm extending beside the popping plate, and a finger pivoted to the periphery of said popping plate opposite each of said compartments and arranged to be moved into position for engaging said arm.

6. In a corn popping machine, a rotatable popping means having compartments with closed tops and a slot in the top of each compartment concentric with the axis of said popping means, a corn feeding chute in position over said feed slots in the compartments and adapted to feed corn to one compartment at a time, means for controlling said feed chute having an arm, and an adjustable finger on said popping means opposite each compartment and movable into position to engage and disengage said arm.

7. In a corn popping machine, rotary popping plate, means for feeding thereto the corn to be popped, means for regulating the operation of said feeding means having an arm projecting down beside the periphery of the popping plate, fingers pivoted in a horizontal position to the periphery of said popping plate adapted when turned radially outward to engage said arm and operate the feeding mechanism and when turned inwardly against the periphery of the popping plate to engage said feed controlling arm, and a weight for returning said feed controlling means after it has been operated by said finger.

8. In a corn popping machine, a popping plate, a cover therefor having compartments with the tops of the compartments fulcrumed between their ends, a lever, means for actuating said lever, and a spring-held pin in the inner end of said lever in position to engage the inner ends of the tops of the compartments in succession so as to successively raise the outer ends thereof and open said compartments.

9. In a corn popping machine, a popping plate, a cover therefor having compartments with the tops of the compartments fulcrumed between their ends, an actuating lever extending over the inner ends of said tops with a hole in the inner end thereof, a

pin with a reduced portion within said hole
 and an upwardly flaring portion above said
 hole, and a spring secured to said lever and
 to the upper end of said pin so as to hold
 5 said pin in position to engage the inner ends
 of the compartments successively and open
 the same.

In witness whereof, we have hereunto af-

fixed our signatures in the presence of the
 witnesses herein named.

JAMES I. HOLCOMB.
 JACOB F. HOKE, JR.

Witnesses:

J. H. WELLS,
 R. G. LOCKWOOD.